

THIS DRAWING IS UNPUBLISHED. RELEASED FOR PUBLICATION
 © COPYRIGHT - By - ALL RIGHTS RESERVED.

LOC	DIST	REVISIONS			
P	LTR	DESCRIPTION	DATE	DWN	APVD
AF	50	Y	REVISED PER ECR-12-013459	28NOV2012	KH PD

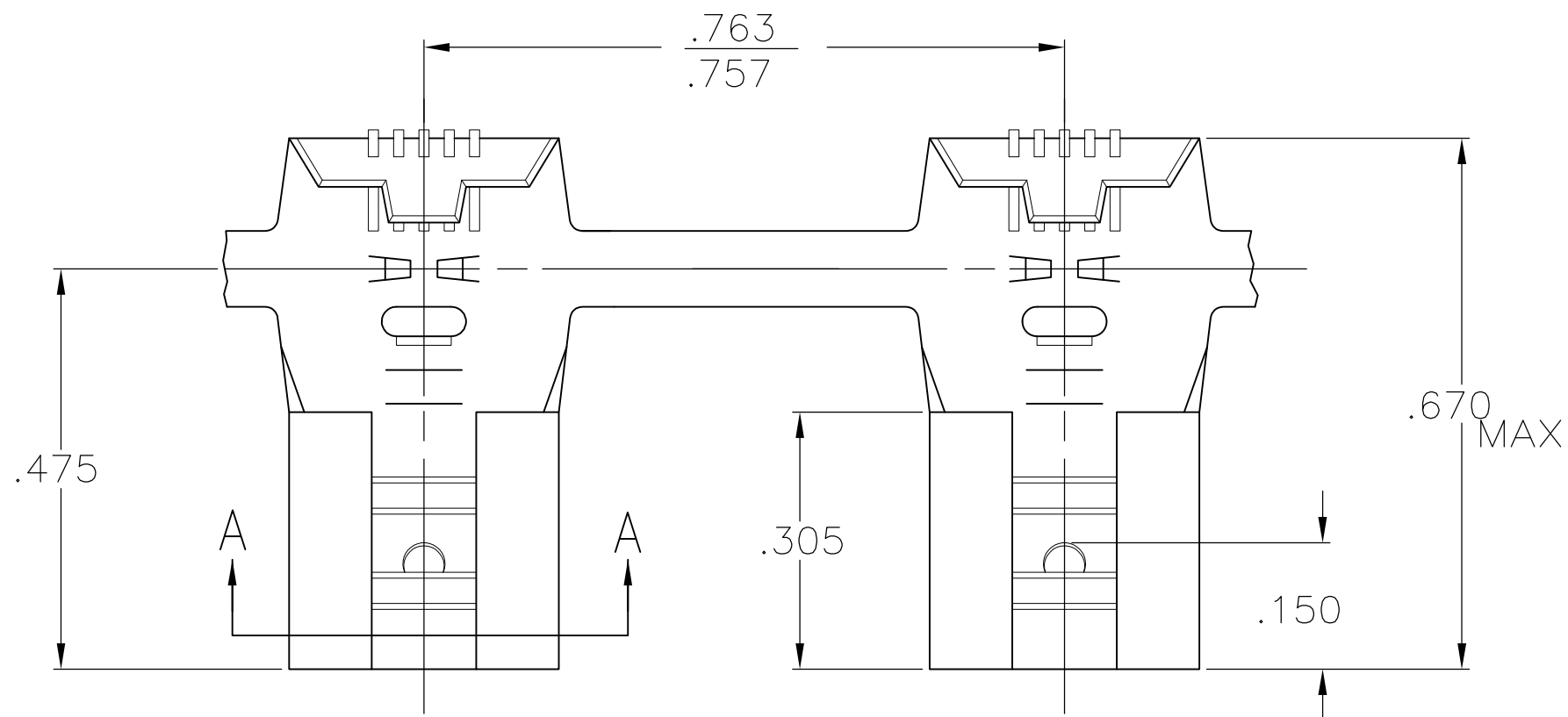

1 CONTINUOUS STRIP ON REELS.

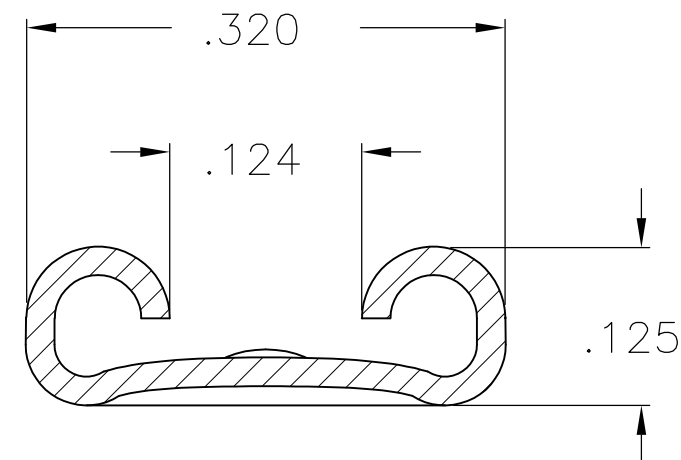

SECTION A-A

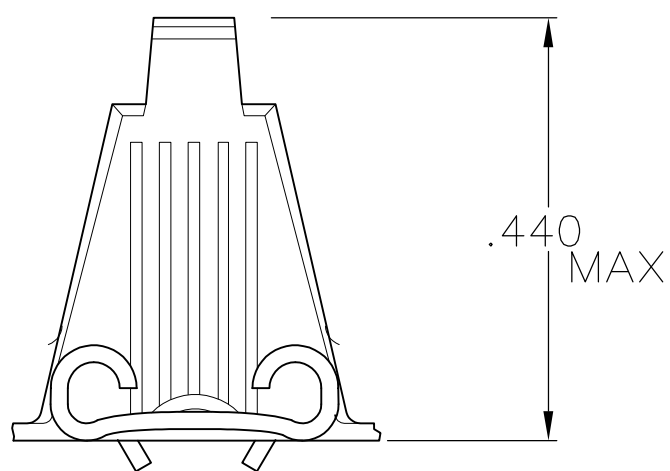

OBSOLETE

REV.	REEL	L.H.	WIRE SIZE	TAB THK	FINISH	MATERIAL	PART NO.
	12-10		.032 ±.001		TIN	.018 PHOS. BRONZE	62057-8
	12-10		.032 ±.001		SILVER	.018 PHOS. BRONZE	62057-7
	12-10		.032 ±.001			.018 BRASS	62057-6
	12-10		.032 ±.001		TIN	.018 PHOS. BRONZE	62057-5
	12-10		.032 ±.001		TIN	BRASS	62057-4
	12-10		.032 ±.001		TIN	BRASS	62057-3
	12-10		.032 ±.001		SILVER	.018 PHOS. BRONZE	62057-1

THIS DRAWING IS A CONTROLLED DOCUMENT.		DWN	JR RUTH	2/3/86	TE Connectivity					
DIMENSIONS: INCHES		CHK	R KUZO	2/7/86				NAME .250 SERIES FLAG FASTON RECEPTACLE		
		APVD	C MEYERS	2/7/86						
TOLERANCES UNLESS OTHERWISE SPECIFIED:		PRODUCT SPEC			SIZE					
0 PLC ± - 1 PLC ± - 2 PLC ± - 3 PLC ± .015 4 PLC ± - ANGLES ± -		APPLICATION SPEC			CAGE CODE					
MATERIAL SEE TABLE		FINISH SEE TABLE			DRAWING NO					
		WEIGHT -			A300779					
		CUSTOMER DRAWING			SCALE 1:1					
					SHEET 1 OF 1					
					REV Y					